

**IMPORTANT:**  
Left Hand Thread  
(Counter-clockwise  
to tighten)

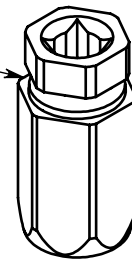

TWC-4N  
(scale 1:1)

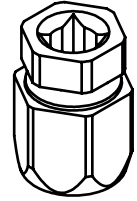

TWC-4S  
(scale 1:1)

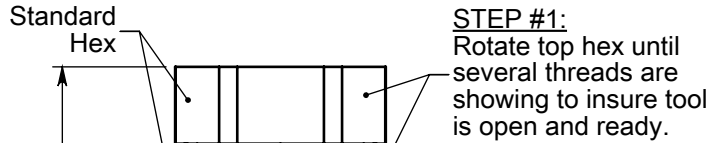

**STEP #1:**  
Rotate top hex until  
several threads are  
showing to insure tool  
is open and ready.

**STEP #R2:**  
Rotate top hex  
clockwise until  
collar falls out.

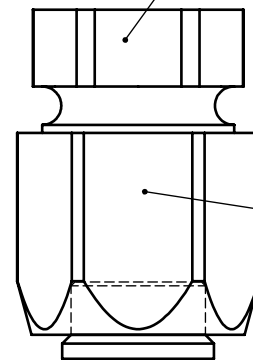

**STEP #R1:**  
Hold bottom  
hex with tool.

## Removing collar from tool.

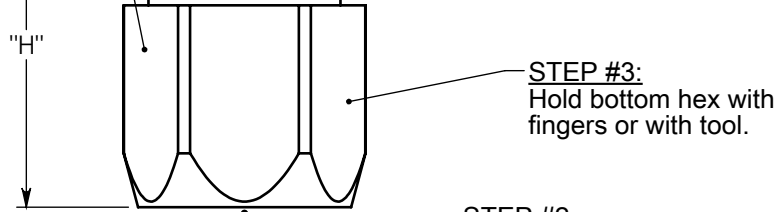

**STEP #2:**  
Place tool down on  
collar until tool  
bottoms out on collar.

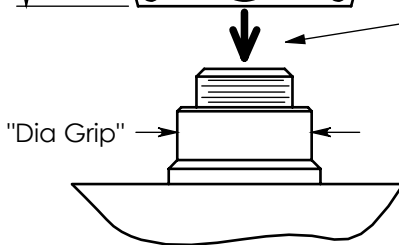

**STEP #3:**  
Hold bottom hex with  
fingers or with tool.

**STEP #4:**  
Rotate top hex counter clockwise until  
TWC tool achieves a firm grip on collar.  
At this point, release bottom hex and  
continue to rotate top hex counter-  
clockwise. The TWC tool will self-  
tighten and unscrew collar.

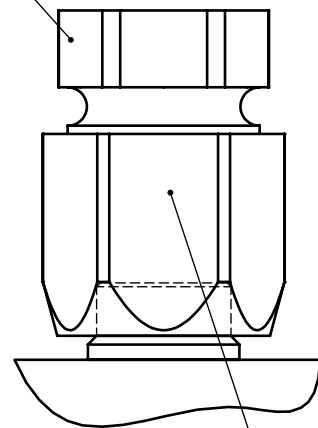

**STEP #3:**  
Hold bottom  
hex with tool  
OR fingers.

## Removing collar from structure.

PART NO.	"H"	"D"	"DRIVE"	"T Hex"	"B Hex"	"DIA Grip"
TWC-2.5N	1.05	0.48	Thru Hole	3/8	7/16	.263/.235
TWC-2.5S	.6	0.48	Thru Hole	3/8	7/16	.263/.235
TWC-3N	1.1	0.48	Thru Hole	3/8	7/16	.300/.265
TWC-3S	.63	0.48	Thru Hole	3/8	7/16	.300/.265
TWC-4N	1.2	0.63	0.25	1/2	9/16	.360/.315
TWC-4S	.8	0.63	0.25	1/2	9/16	.360/.315
TWC-4AN	1.25	0.70	0.25	9/16	5/8	.405/.360
TWC-4AS	.83	0.70	0.25	9/16	5/8	.405/.360
TWC-5N	1.3	0.85	0.25	5/8	3/4	.460/.410
TWC-5S	.9	0.85	0.25	5/8	3/4	.460/.410
TWC-6N	1.4	0.92	0.25	11/16	13/16	.532/.480
TWC-6S	1.1	0.92	0.25	11/16	13/16	.532/.480
TWC-7N	1.5	1.06	0.375	3/4	15/16	.634/.555
TWC-7S	1.15	1.06	0.375	3/4	15/16	.634/.555
TWC-8	1.71	1.38	0.5	1.0	1 1/4	.710/.640
TWC-9	1.71	1.38	0.5	1.0	1 1/4	.780/.710
TWC-10	1.71	1.38	0.5	1.0	1 1/4	.870/.800
TWC-10A	1.71	1.38	0.5	1.0	11/4	.940/.870

**CENTRIX LLC**

25329 74th Ave S.  
Kent, WA. 98032  
253-872-4773  
www.centrix-llc.com

## Frangible Collar Removal Tool

Part Definition Sheet

Description: REMOVES FRANGIBLE COLLARS

SHEET 1 of 1